

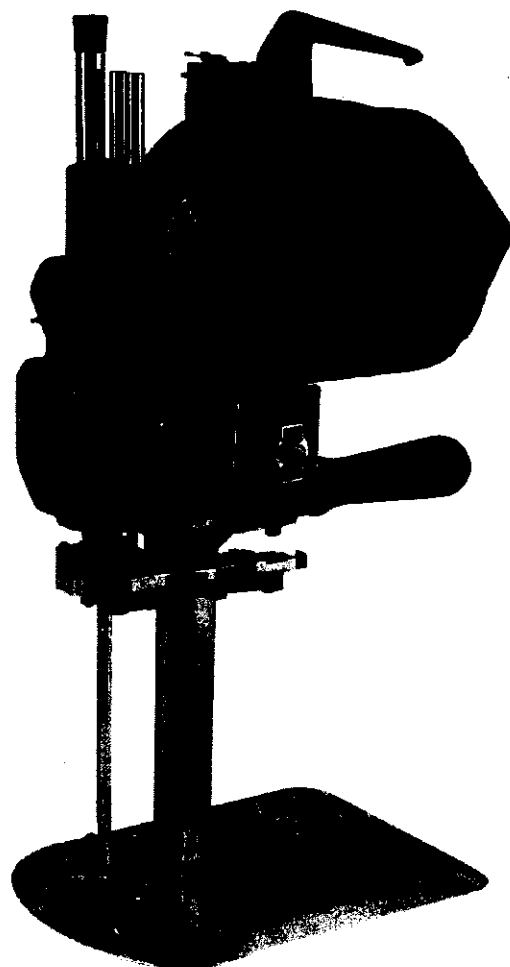

CE

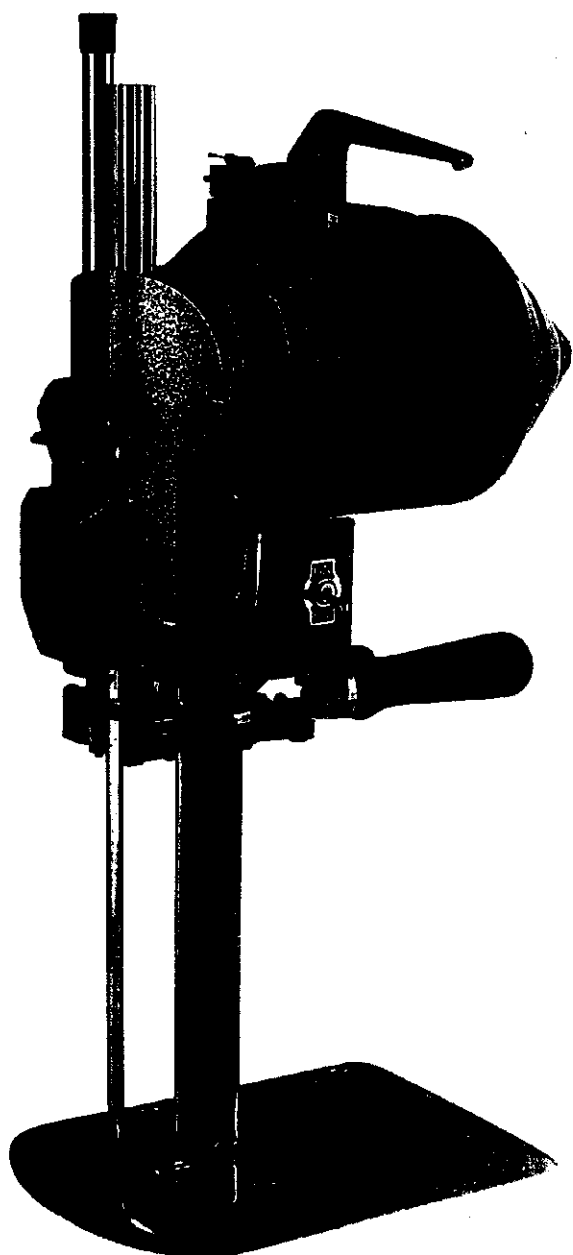

使用前应向油杯内加油；将电机后的旋钮推入转几转，刀片应能上下灵活移动。

Before operating the motor, be sure that electric supply voltage and current are the same as stamped on the nameplate. Fill oil cup. Push in turning knob and turn the machine over a few revolutions by hand to see if the knife moves easily.



在机器连续运转之前，应将机器通电开闭几次，可使油预热，使油润滑各运动部件。

The motor should be turned on and off a few times before running continuously. This permits the oil to warm up and flow easily into the closely fit moving parts.

油杯 T 中的油应位于上下线之间，不要用缝纫机油，请使用30~50号机油。

In the cup A oil level be keeping up to red line. Do not use sewing machine oil. Use No 30~50 motor oil.

当心刀片快口伤人。操作时请使用木手柄推动机器，搬动机器时，请使用提手柄。

This machine is equipped with a sharp knife, Keep hands away from the knife area at all times. Use control levers and handles only when operating or handling machine

未装刀片时切勿磨刀，以免造成机器损坏。

Do not operate sharpener without knife in machine or the sharpener will be damaged.

请放下压脚，用力慢慢地按下磨刀手柄。如果轧死，请抬起拨叉，重新再来几次后，你便会知道怎样的轻重最适合。

Take the machine out of the lay. Drop pressure foot by means of pressure foot lever located next to machine operating handle. Press release lever downward with a slow, firm pressure to engage sharpening mechanism. Too fast lever action may cause lever to lock. If this occurs, lift latch lever and start Lever. After a few tries you will feel correct operating pressure.

▲当用户更换新刀片时，应该旋转电机后端的旋钮C使刀片处于最下端，并使刀锋最低点A位于脚板平面B下2~3mm。

▲Do change the new knife, shall turn "C" to bottom, and make knife sharp lowest point "A" to below 2-3mm of the plate "B"

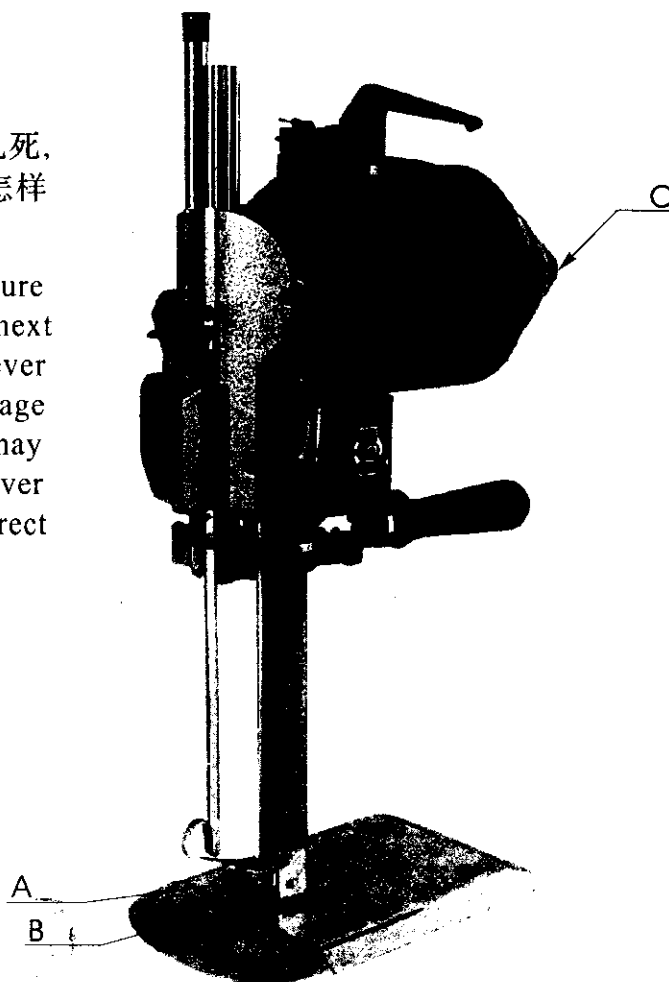

底盘刀库部分  
 STAND&BASE PLATES  
 代号 (KA)

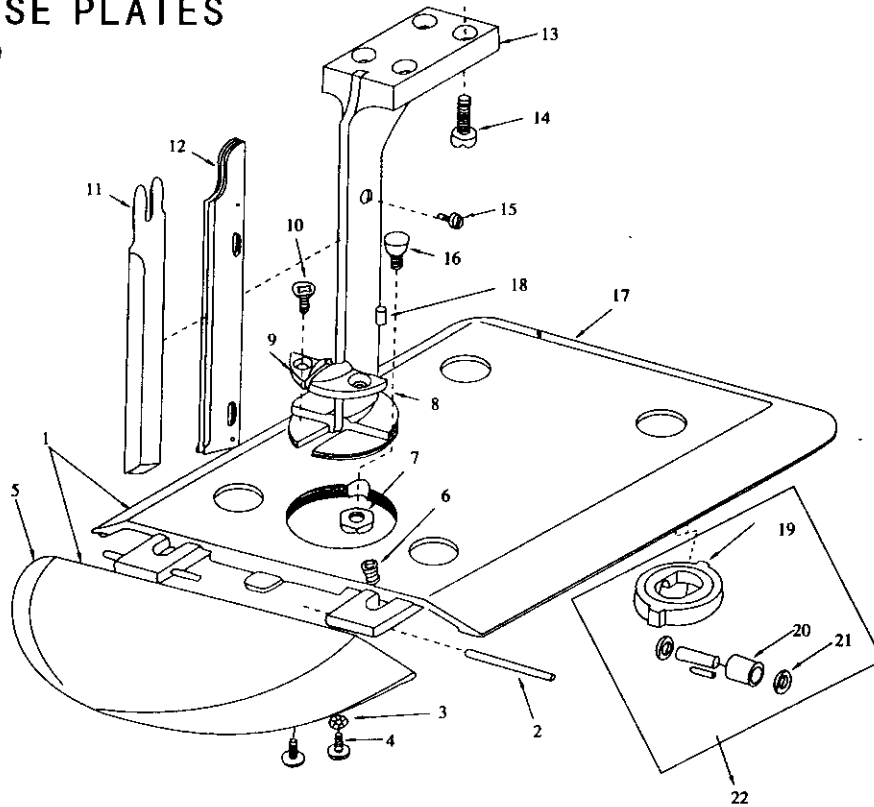

零件号 Part No.	名称	Desonription	数量 No.Req'd	备注 Remarks
KA1	底板全套	Complete plate	1	M078
KA2	芯轴	Hinge Pin Short	2	M081
KA3	外齿锁紧垫圈4	Clamp Washer 4	4	M089
KA4	底盘螺钉	Hinge Pin Clamp Screw	4	M082
KA5	盘翼	Plate Wing	1	M077S
KA6	弹簧	Plate Wing Tension Spring	2	M091
KA7	六角螺母	Plate Nut	1	M090
KA8	右刀库舌	Right Throat Plate	1	} M088
KA9	右刀库舌	Lift Throat Plate	1	
KA10	螺钉M4×10	Screw M4x10	2	M087
KA11	刀片	Knife	3	M191
KA12	衬片组合	Knife Side	1	M086
KA13	刀库	Standard	1	M085
KA14	螺钉M6×20	Screw M6x20	4	M084
KA15	螺钉M3×5	Screw M3x5	3	M084
KA16	销	Spin	1	M090
KA17	底盘	Plate	1	M077L
KA18	销4×10	Spin 4×10	2	
KA19	滚子架组合	Roller Rack Assy(Rwbber)	4	M080R
	滚钉5×19.8	Round Head Rolling Pin 5×19.8	4	
KA20	滚子	Roller	4	M080C
KA21	垫圈5	Washer 5	8	
KA22	全套滚轮	Rubber Mounted Roler Complete	4	M080

前端盖部分  
 FRONT COVER MECHANISM  
 代号 (KA)

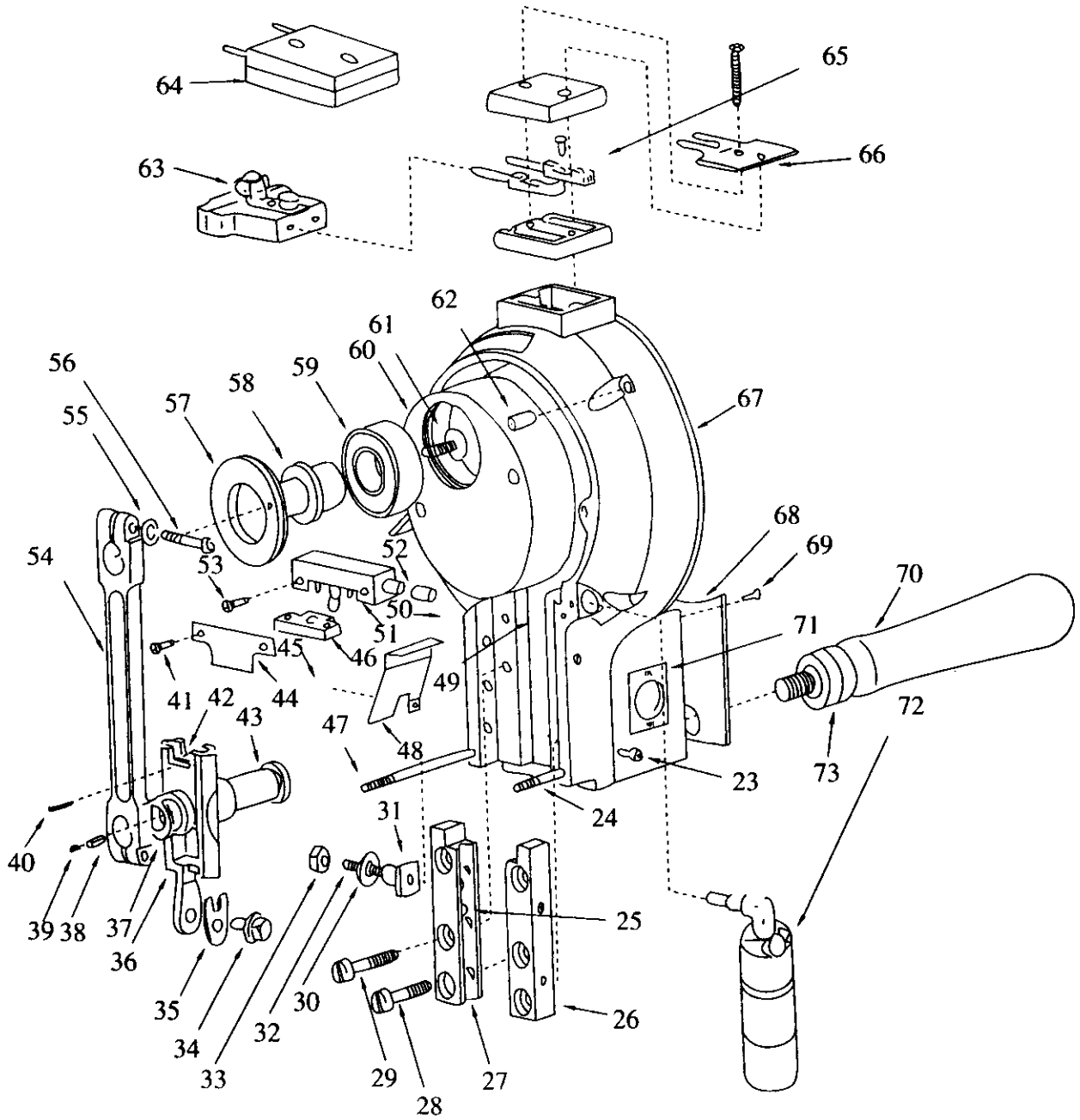

零件号 Part No.	名称	Description	数量 No. Req'd	备注 Remarks
KA23	螺钉M4×8	Screw M4×8	2	
KA24	短双头螺栓	Short Stud	1	M062
KA25	滑轨油毡	Guide Felt	2	
KA26	右侧滑轨	R.H. Guide	1	M048

零件号 Part No.	名称	Description	数量 No. Req'd	备注 Remarks
KA27	左侧滑轨	L.H. Guide	1	M049
KA28	螺钉	Screw	3	M047
KA29	螺钉	Screw	3	M047
KA30	垫圈	Washer	3	M043
KA31	方头调节螺母	Guid Adjusting Nut	3	M046
KA32	螺钉M5×20	Screw M5×20	3	M045
KA33	螺母M5	Nut M5	3	M042
KA34	方头螺钉	Square Screw	1	M051
KA35	方头螺钉垫	Knife Lock Washer	1	M041
KA36	滑枕	Cross Head	1	M050
KA37	垫片	Connecting Rod Washer	1	M044
KA38	油毡	Oil felt	1	
KA39	油堵	Wrist Pin Plug	1	M040
KA40	铆钉 1.6×9	Rivets 1.6×9	2	
KA41	螺钉M2.5×4	Screw M2.5×4	2	M211
KA42	油毡	Oil Felt	1	
KA43	滑枕轴	Wrist Pin	1	M039
KA44	防油板	Oil Plate	1	M210
KA45	螺钉M3×3	Screw M3×3	2	M213
KA46	油毡	Oil Felt	1	
KA47	双头螺栓	Stud	1	M060 M061
KA48	防油板	Oil Guard	1	M212
KA49	螺钉M4×4	Screw M4×4	1	M054
KA50	空心棉丝绳3×150	Oil Felt 3×150	1	M033
KA51	导油管座	Oil Pad Holder	1	M032
KA52	导油管套	Oil Tude	1	M209
KA53	螺钉M3×16	Screw M3×16	2	
KA54	连杆	Connecting Rod	1	M036
KA55	垫圈4	Washer 4	2	M037
KA56	螺钉M4×16	Screw M4×16	2	M038
KA57	轴承盖	Bearint Cover	1	M029
KA58	轴承轴	Bearing Shaft	1	M030+031
KA59	轴承80201 D	Bearing 80201 D	1	M064
KA60	曲柄	Crank	1	M027
KA61	轴承轴螺钉	Screw for Brg Shaft	1	
KA62	螺母	Front to Rear Bearing Nut	4	M057
KA63	插头组合	Attachment Plug	1	M069
KA64	插头组合	Termial Block	1	M070
KA65	插头蕊	Terminal sleeve	2	M071+072
KA66	插座联接板	Ground Clip	1	M066
KA67	前端盖	Frount bearing Housing	1	M055
KA68	后盖板	Switch Cover	1	M215
KA69	螺钉M3×5	Screw M3×5	4	M075
KA70	手柄	Operating Handle	1	M073
KA71	开关牌	Switch Plate	1	
KA72	油杯	Oil Cup	1	M034+035
KA73	锁紧螺母	Clutch Nut	1	M074

电机部分  
MOTOR&HOUSTNG MECHANISM  
代号 (KA)

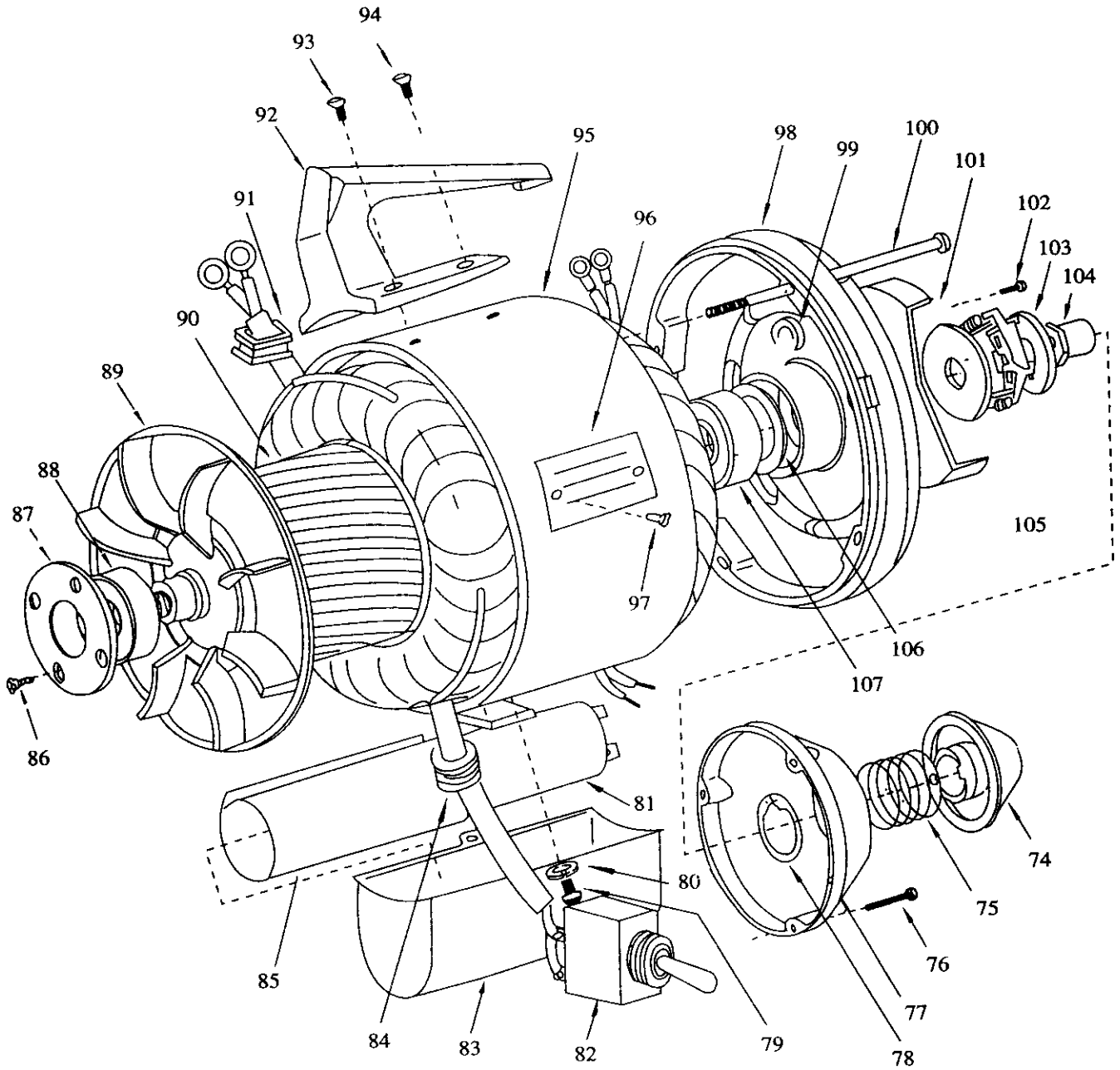

零件号 Part No.	名 称	Desonription	数 量 No.Req'd	备注 Remarks
KA74	手 轮	Turning Knob	1	M009
KA75	离合器弹簧	Clutch Spring	1	M021
KA76	螺钉M3×16	Screw M3×16	4	M006
KA77	防尘盖	Dusr Cap	1	M008
KA78	轴用弹性挡圈	Retaining Ring	1	M022
KA79	螺钉M4×6	Serew M4×6	2	M205
KA80	垫 圈4	Washer 4	2	
KA81	电容器具100μF	Capacitor 1 00 μF	1	M206
KA82	扭子开关	Switch	1	M020
KA83	电容器盒	Capacitor Cover	1	M204+205
KA84	电线护套	Wire Sleeve	1	
KA85	电容器垫2.5×60×100	Wool Fabric	1	
KA86	螺钉M3×10	Screw M3×10	1	
KA87	前轴承盖	Fornt Bearing Cover	4	M065
KA88	轴承80202D	Bearing 80202D	1	M023
KA89	风 扇	Fan	1	M003
KA90	转 子	Rotor With Shaft	1	M004
KA91	电线护套	Wire Sleeve	1	
KA92	提 手	Carrying Handle	1	M203
KA93	螺钉M4×18	Screw M4×18	2	
KA94	螺钉M4×16	Screw M4×16	2	
KA95	定 子	Capacitor-Stator	1	M001
KA96	铭 牌	Skin Cover	1	
KA97	螺钉M2.5×4	Screw M2.5×4	2	M002
KA98	后端盖	Rear Bearing Housing	1	M007
KA99	电线护套	Wire Sleeve	1	M005
KA100	长螺钉	Long Screw	2	M013+014
KA101	绝缘盖	Insulate Cover	2	M200
KA102	螺钉M4×10	Screw M4×10	2	
KA103	离合器螺母	Clutch Nut	1	M025
KA104	锁紧螺母	Shaft Lock Nut	1	M026
KA105	离心开关	Automatic Cut-out Switch	1	M201+202
KA106	波形弹簧片	Wssher With Vave	1	M024
KA107	轴承80201D	Bearing 80201D	1	M023/028



零件号 Part No.	名 称	Desonription	数 量 No.Req'd	备注 Remarks
KA108	凸轮罩盖	Cam Cover	1	M101
KA109	螺钉M4×10	Screw M4×10	4	M099
KA110	压紧弹簧	Spring	1	M109
KA111	齿板轴	Shaft for Great Plate	1	M121
KA112	齿 板	Gear Plate	1	M120
KA113	压脚导板	Slide for Pressure Foot	1	M122
KA114	螺母M4	Nut M4	1	
KA115	弹簧螺钉	Screw for Spring	1	M098
KA116	凸轮弹簧	Spring for Cam	1	M111
KA117	凸轮轴	Shaft for Cam	1	M097
KA118	变向柄螺轴	Screw Shaft for Latch	1	M096
KA119	变向弹簧	Spring for Cam	1	M110
KA120	变向柄	Latch for Cam	1	M124
KA121	凸轮轴套	Bearing for Cam Shaft	2	
KA122	凸轮螺钉	Screw for cam	1	M118S
KA123	螺钉M4×6	Screw M4×6	1	M117
KA124	变向凸轮	Cam	1	M118C
KA125	压脚下导板	Lower Slider for EF Rod	1	M123
KA126	手柄螺钉	Screw Shaft for Latch	1	} M119
KA127	弹簧垫	Spring Washer	1	
KA128	垫 圈5	Washer5	1	
KA129	磨刀于柄组合	Sharpening Lever	1	M218
KA130	六角头螺钉	Hexagon-headed Screw	1	
KA131	六角螺母	Hexagon-headed Screw	1	M152
KA132	压角杆提手	Pressure Foot Lift	1	M230
KA133	螺钉M3×5	Screw M3×5	2	
KA134	螺钉M3×6	Screw M3×6	2	M133
KA135	传动轮盖	Cover for Driving Pulldy	1	M134
KA136	磨削器外罩	Sharpener Housing	1	M127
KA137	传动管	Tube for Driving	1	M093

零件号	名 称	Desonription	数 量	备注
Part No.			No.Req'd	Remarks
KA138	导向管帽	Cap for Tube	1	M092
KA139	方轴导向管	Tube for Square Shaft	2	M094
KA140	油垫	Felt Pad for Cross Head	1	M232
KA141	螺 轴	Screw Shaft	1	M233
KA142	齿轮轴	Gear & Shaft	1	M144
KA143	曲 拐	Bell Crank With Pin&Bushing	1	M132
KA144	轴承80018D	Bearing 8001 8D	2	M149
KA145	轴承垫	Washer for Bearing	1	
KA146	挡圈22	Lock Ring 22	1	M155
KA147	传动轮	Driving Pulley	1	M146
KA148	传动斜齿轮轴	Shaft for Crank	1	M153
KA149	传动斜齿轮	Idler Gear With Bushing	1	M156
KA150	长轴齿轮上套	Bearing for drive Shaft	2	M151
KA151	垫	Thrust Washer	2	
KA152	键	Key	1	} M157
KA153	键槽斜齿轮	Spiral Gear	1	
KA154	长轴齿轮下套	Bearing for Drive Shaft	1	
KA155	螺钉M 5×1 4	Screw M5×14	2	M100S/L
KA156	挡圈6	Lock Ring 6	1	M150
KA157	垫	Washer	1	M154
KA158	弹簧挡销	Pin for S harpener Housing	1	
KA159	弹 簧	Spring	1	} M126 L U
KA160	销 轴	Pin for bell Crank	1	
KA161	止动杆	Push Rood	1	M139
KA162	销1.5×10	Pin 1.5×10	1	M140
KA163	螺钉M3×12	Scre M3×12	1	M142
KA164	分离块	Spreader Pin	1	M143
KA165	外罩底盘	Bottom Plate	1	M129
KA166	螺轴套	Screw Shaft Sleeve	1	
KA167	螺 轴	Screw Shaft	1	

零件号 Part No.	名 称	Desonription	数 量 No.Req'd	备注 Remarks
KA168	油盘组合	Oil Pad and Holder	1	M130
KA169	螺钉M4×6	Screw M4×6	1	M131
KA170	螺钉M4×12	Screw M4×12	3	M128
KA171	方孔齿轮套	Bearing for Gears	2	M145
KA172	方孔齿轮	Squr Gear	2	M148
KA173	长轴齿轮	Driver Shaft with Gear	1	M141
KA174	螺杆导套	Screw Shaft Sleeve	1	
KA175	螺 母	Nut	3	
KA176	压脚手柄弹簧	Spring for Prssure Foot Lever	1	M116
KA177	压脚手柄螺钉	Pre s sure Fott Lever S crew	1	M115
KA178	压脚手柄	Prssure Foot Lever	1	M217
KA179	压肢杆	Prs sure Foot Rod	1	M216
KA180	压 脚	Pressure Foot Shoe	1	M219
KA181	螺钉M4×10	Screw M4×10	2	M113
KA182	螺钉M4×20	Screw M4×20	1	M100L
KA183	螺钉M4×10	Screw M4×10	1	M100S
KA184	弹 簧	Spring	1	

砂带磨削部分  
 LOWER GEAR BRACKET MECHANISM  
 代号 (KA)

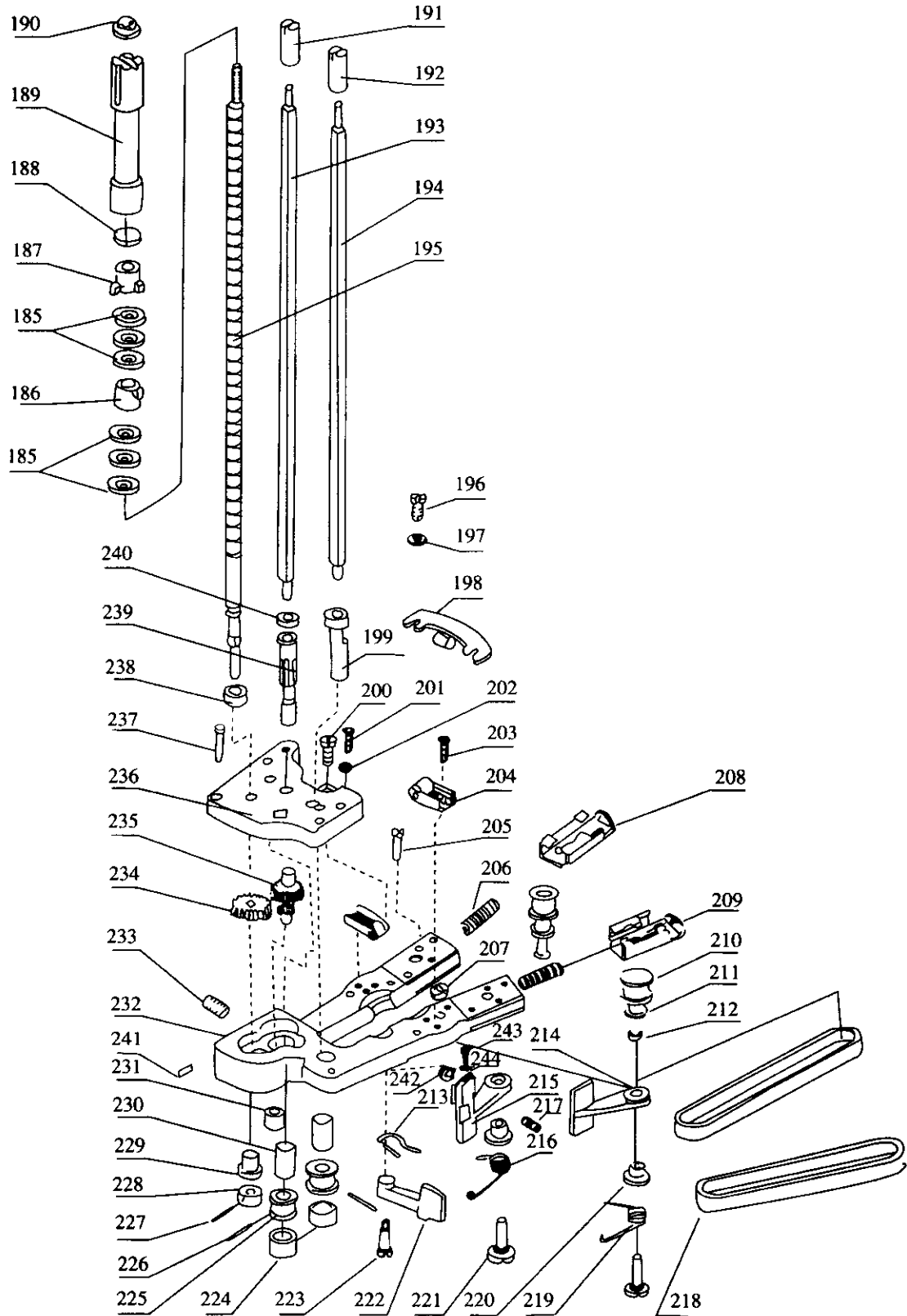

零件号 Part No.	名 称	Desonription	数 量 No.Req'd	备注 Remarks
KA185	推力轴承组合	Thrust Ball Bearing	2	M229
KA186	右旋螺母	Nut for Screw Shaft R. H	1	} M104
KA187	左旋螺母	Nut for Screw Shaft L. H	1	
KA188	左螺母垫	washre for Screw haft L.H	1	M105
KA189	调节套筒	Space Tube	1	M107
KA190	调节螺母	Stop Nut for Screw Shaft	1	M108
KA191	左方轴导向柱	Left Hand Fllower Nut	1	M137
KA192	右方轴导向柱	Right Hand Fl lower Nut	1	M135
KA193	左方轴	L. H Square Shaft	1	M138
KA194	右方轴	R. H Square shaft	1	M136
KA195	往复螺轴	Screw Shaft with Extension	1	M106
KA196	螺钉M4×8	Screw M4×8	2	} M175
KA197	垫 圈	Washer	2	
KA198	后导轮架组合	Guide Back of Standard	1	M173
KA199	右方轴下轴	Lower Shaft for R. H Square Shaft	1	
KA200	螺钉M3×12	Screw M3×12	1	
KA201	螺枪M4×10	Adjusting Screw M4×10	1	M165S
KA202	螺母M4	Nut M4	1	M165N
KA203	螺钉M3×6	Screw M3×6	4	M161
KA204	平衡架组合	Stabilizer	2	M172
KA205	螺钉M3×5	Screw M3×5	2	M163
KA206	涨紧轮弹簧	Spring for Pulley Slider	2	M181
KA207	螺母M5	Nut M5	2	M184
KA208	左涨紧轮导架	L. H. Slider	1	} M176
KA209	右涨紧轮导架	R. H. Slider	1	
KA210	涨紧轮	Tension Pulley	2	} M177
KA211	涨紧轮轴套	Shaft Sleeve with Tension Pulley	2	
KA212	涨紧轮轴	Shaft with Tension Pulley	2	
KA213	限位调节弹簧	Spring for Arm	1	M188
KA214	右夹板	R. H. Shoe	1	M169

## 附件 *Accessories*

零件号 Part N0.	名称	Description	数量
KA11	刀片	Knife	1
KA218	砂带	Belt	10
KA255	六角套筒	Square Sleeve	1
KA256	四角套筒	Square Sleeve	1
KA257	内六角扳手	Wrench	2
KA258	螺丝刀	Screw Driver	1
KA259	清扫器	Cleaner	1
KA260	电源线插头组件	Attachment & Wire Plug	1
KA261	油壶	Oilcan	1

## 12"、10"、8"、6" 不同尺寸零件表 *Different Size Parts List*

零件号 Part N0.	名称	Description	尺寸规格Size			
			12"	10"	8"	6"
KA11	刀片	Knife	344	294	244	194
KA12	衬片组件	Knife Side	319	269	219	169
KA13	刀库	Standard	324	274	224	174
KA137	传动管	Tube for Driving	294	244	194	194
KA139	方轴导向管	Tube for Square Shaft	295	245	195	195
KA179	压肢杆	Prssure Foot Rod	414	364	314	264
KA193	左方轴	L.H Square Shaft	347	297	247	197
KA194	右方轴	R.H Square Shaft	347	297	247	197
KA195	往复螺轴	Screw Shaft with Extension	419	369	319	269