

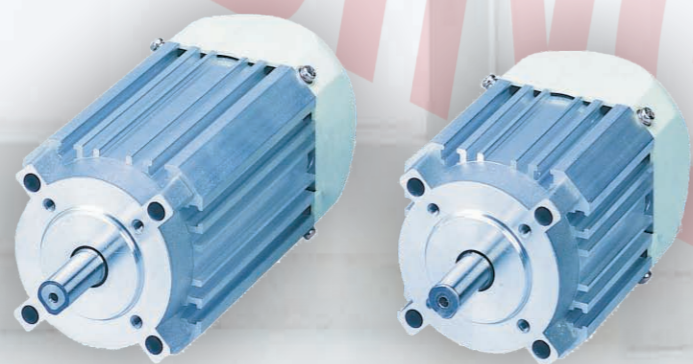

HVP-70 SERIES AC SERVO MOTOR

專業級的選擇
滿足您的需求

THE PRO'S CHOICE
SATISFY YOUR NEEDS



POWERFUL AND RELIABLE

Specification / 規格

Function	機能	HVP-70-3	HVP-70-4
Motor Type	馬達出力	500W-5000 rpm.	
		600W-3500 rpm.	
		750W-2500 rpm. / 750W-3500 rpm.	
Power Voltage Range	電壓範圍	Single Phase : 100~120V / 200~240V	
		Three Phase : 200~240V	
Pulley Size Available	皮帶輪尺寸	55~85 mm	
Needle Up / Down	停針 上 / 下	★	★
Soft Start	慢速啟動	★	★
Presser Foot Lifting	押腳提昇	★	★
Trimmer / Wiper	切線 / 掃線	★	★
Automatic Back-Tacking	自動回縫	★	★
Reverse at Stop	停針反轉	★	★
Power Transistor Protection	電晶體過載保護	★	★
Power Module Protection	模組保護	★	★
Input Signal Port	入力信號數	2	2(10-Option)
Solenoid Signal Output Port	電磁閥出力信號數	4	8(4-Option)
Edge Sensor Input Port	電眼輸入信號數	0	2
Gross Weight	毛重	500W :9.9 / 600W :10.3 / 750W :10.9 kg	
Packing Dimension	包裝外部尺寸	400L X 350W X 320H mm	

Dimension / 尺寸圖

Control box / 控制箱

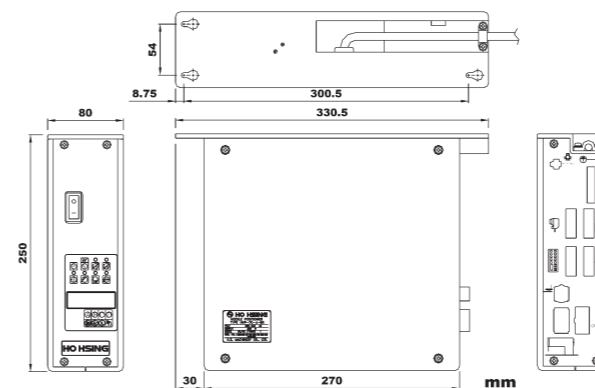

Motor / 馬達

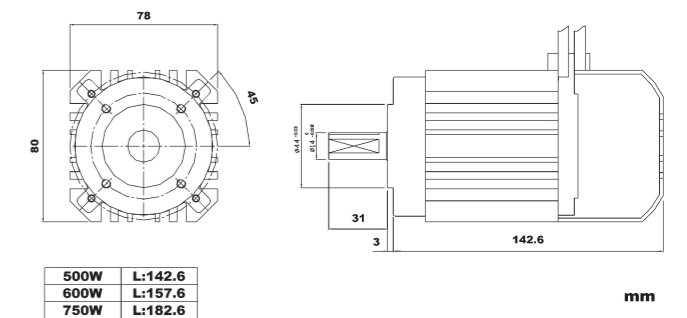

Model Code / 編碼規則

Control box / 控制箱

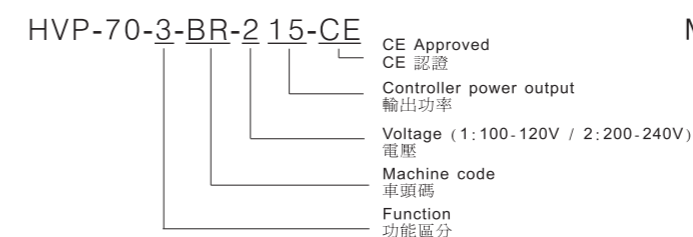

Motor / 馬達

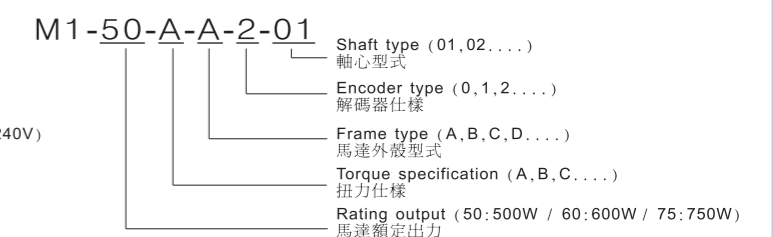

All the technical data, dimensions and weights are for reference only, and are subject to change without notice. For other products information please contact our sales representative or visit our web site at www.hohsing.com



賀欣機械廠股份有限公司
H.S.MACHINERY CO., LTD.

台北縣樹林市中正路632巷5號
NO. 5 LANE 632 CHUNG CHENG RD.,
SHULIN CITY, TAIPEI HSIEN, TAIWAN
TEL : +886-2- 2689-5501~2 (REP.)
+886-2- 2688-5742, 2688-6044
SERVICE : +886-2676-5203
FAX : +886-2- 2689-6600, 2689-3657
E-MAIL : sales@hohsing.com.tw

<http://www.hohsing.com>



賀欣機械廠股份有限公司
H.S.MACHINERY CO., LTD.

HVP-70 SERIES AC SERVO MOTOR

Reliable control and full function design
穩定操控及全功能設計

FEATURES / 特性

1. Highly accurate positioning.
 2. Multi- Positioning mode.
 3. Low noise、low vibration and low power consumption.
 4. Software / Hardware 2-way protection system.
 5. Solenoid over current protector.
 6. Switching power supply system. (160V~280V AC)
 7. Powerful parameter system, easy adjustment and upgradable.
 8. Self-Diagnostic function.
 9. Only one circuit board inside, easy for maintenance.
1. 定位準確度高。
 2. 多種定位模式。
 3. 低振動、低噪音、低耗能。
 4. 軟硬體雙向保護機能。
 5. 電磁閥過電流保護。
 6. 交換式電源供應系統。(160V~280V AC)
 7. 多元化的參數系統，設定簡單，參數可升級。
 8. 自我診斷功能。
 9. 內部只有一片基板，維護簡單。

AC MOTOR / AC 馬達

- 500W for general machine head.
 - 600W good for chain-stitch machine
 - 750W for special or heavy duty machine head.
- 500W 適用於一般車頭。
 - 600W 適用於三本車。
 - 750W 適用於特種車及重載車頭。



7-SEGMENT DISPLAY / 七段顯示器

- 7-segment display, LED bright and clear.
 - Parameter setting keys.
 - Function keys.
- 七段顯示器，LED燈光顯示清晰。
 - 參數設定鍵。
 - 功能鍵。

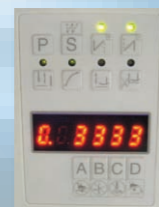

SEWING QUALITY / 車縫品質

Suitable for most fabrics and leather materials
一般布料及皮革皆適用



Stitch length changeable
縫目切替選擇

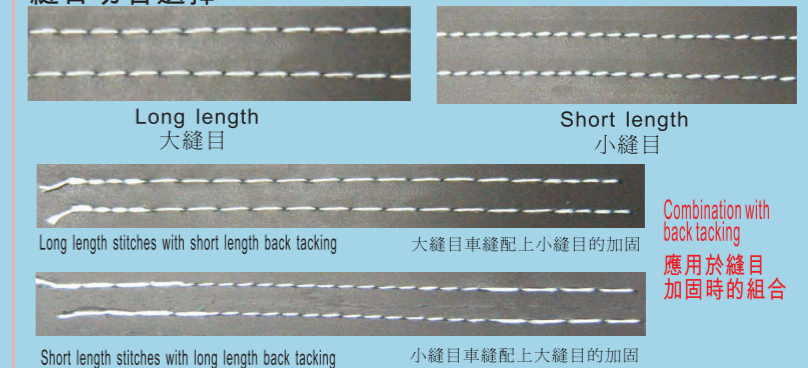

Back tacking (Reverse sewing) / Bar tacking
縫目加固(回縫) / 連續加固

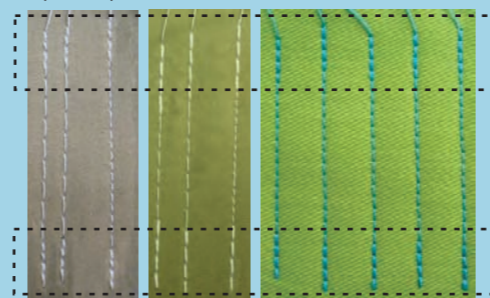

Start back tacking
前加固

Beautiful finish
加固漂亮

End back tacking
後加固

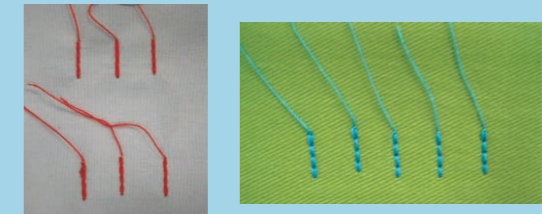

Bar tacking
連續加固

Stitches of back tacking and bar tacking can be adjusted by the display panel or operation box.
前/後加固及連續加固針數可由顯示面板或選針盒來做調整

多功能可定義 I/O 設計
共多達 26 組 I/O 可由參數設定調整

Multi-function definable I/O port design
Total up to 26 sets of I/O port can be set and adjusted by the parameter

OPERATION BOX / 選針盒

- Stitches are clearly displayed on the LCD.
 - Start / End back tacking can be set in 1~15 stitches.
 - Pattern sewing can be set in 1~99 stitches.
 - Linkable to PC.
- 液晶顯示設定參數。
 - 起始 / 終止回縫針數設定範圍 1~15 針。
 - 定針直縫針數設定範圍 1~99 針。
 - 可與電腦連線。

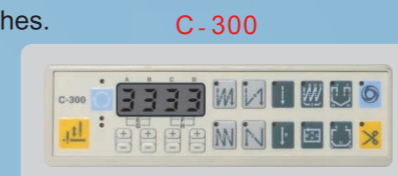

C-300 -- For Standard Mounting
C-300B1 -- For Brother Built-in

SPEED CONTROL UNIT / 控速器

- Stand alone design.
 - Easy install and adjustment.
- 獨立式設計。
 - 安裝及調整簡單。



高相容性及高搭配性於各型縫紉機或特殊裝置
Highly compatible and adaptable in application for sewing machine or special device.